

ASSOCIATED RC10

ASSEMBLY AND OPERATING INSTRUCTIONS

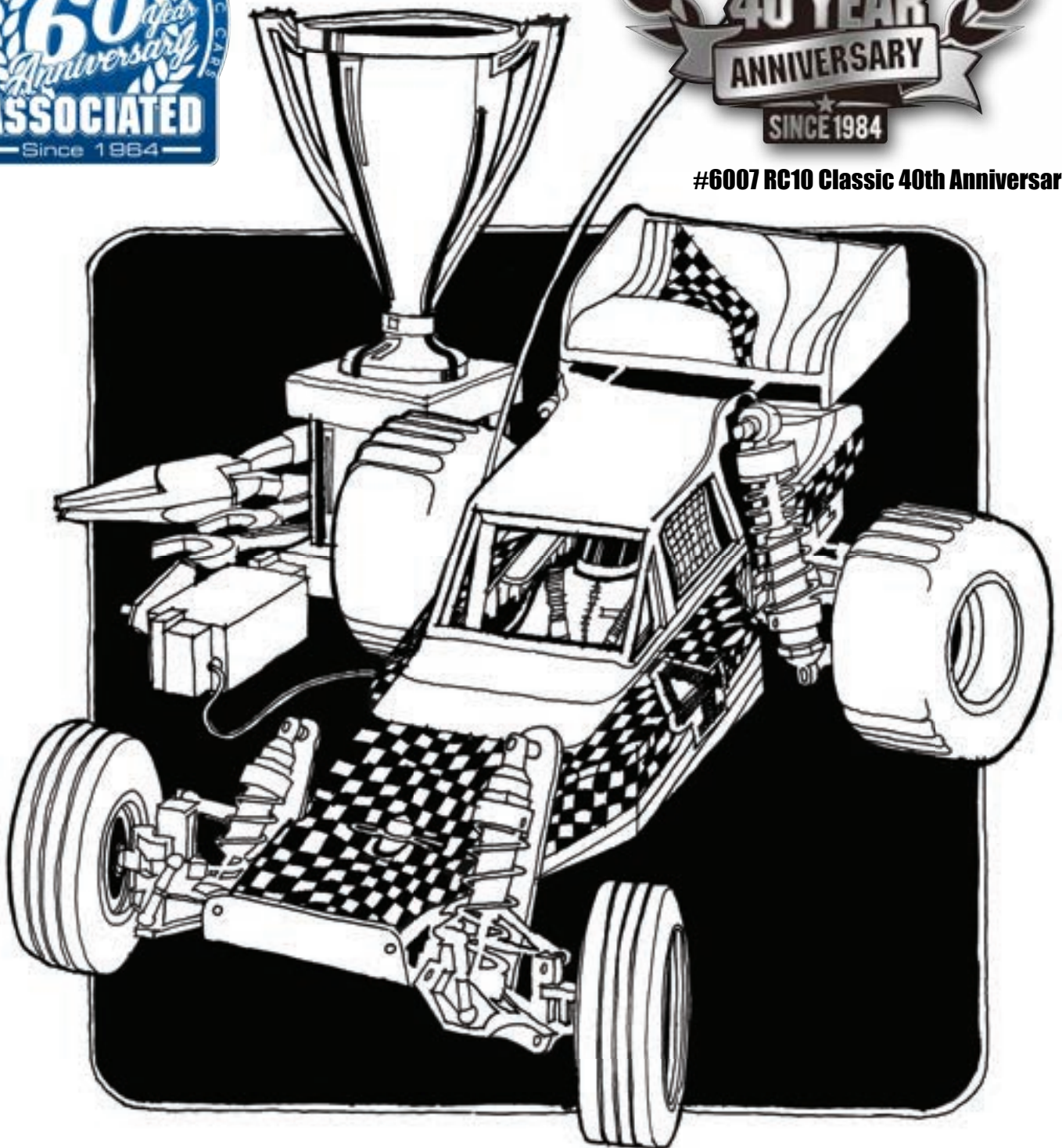

#6007 RC10 Classic 40th Anniversary - Kit



:: Introduction

Thank you for purchasing this Team Associated product. This assembly manual contains instructions and tips for building and maintaining your new RC10 Kit. Please take a moment to read through this manual to help familiarize yourself with these steps.

We are continually changing and improving our designs; therefore, actual parts may appear slightly different than in the illustrations. New parts will be noted on supplementary sheets located in the appropriate parts bags.

Check each bag for these sheets before you start to build.

:: KIT Features

Features in the RC10 - Kit:

- Authentic replica of the RC10 Buggy Kit originally released in 1984
- Anodized 6061-T6 aluminum monocoque tub chassis
- Fully adjustable four wheel independent suspension
- Long travel, fluid filled aluminum coil over shocks
- Low profile sealed six-gear transmission
- VariLok adjustable ball differential
- Exceptional ground clearance with low center of gravity
- Classic AE front and rear tires with modular racing wheels
- Clear ProTech body with driver figure and wing
- Fiberglass shock towers
- Oilite bushings throughout
- Fits 6-cell NiMh and 2S LiPo battery packs

:: Additional

Your new RC10 Kit comes as a kit. There are some items you will need to complete your kit (refer to website for suggestions):

- RC two channel surface frequency radio system
- Electronic Speed Control (ESC)
- Steering Servo
- 2S, 7.4V Lipo stick battery or 7.2V NiMH battery
- Peak detection battery charger
- Retaining Ring Pliers
- Polycarbonate specific paint
- Pinion gear, size to be determined by type and wind of motor you use
- R/C Electric Motor
- Servo Horn (AE #89007)
- Thread Lock (AE #1596)

Tools included:

- Allen wrenches (.035", .050", 1/16", 3/32")
- Shock building tool

:: Other Helpful Items

- Silicone Shock Fluid (Refer to website for complete listings)
- Tire Adhesive (AE #1697)
- Shock Pliers (AE #1681)
- Wire Cutters / Hobby Knife
- Body Scissors (AE #1737)
- Green Slime shock lube (AE #1105)
- Needle Nose Pliers
- Reamer / Hole Punch (AE #1499)
- Calipers or a Precision Ruler
- Soldering Iron

Associated Electrics, Inc.
21062 Bake Parkway
Lake Forest, CA 92630



Customer Service
Tel: 949.544.7500
Fax: 949.544.7501

:: Hardware - 1:1 Scale View

Cap Head (shcs)

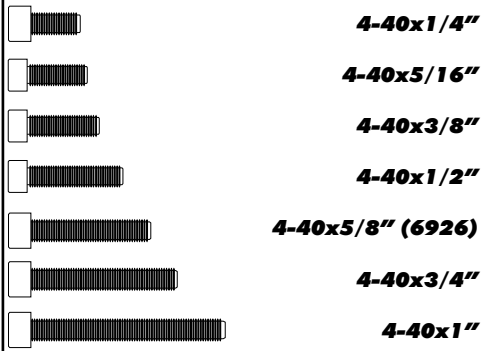

Flat Head (fhcs)



Button Head (bhcs)

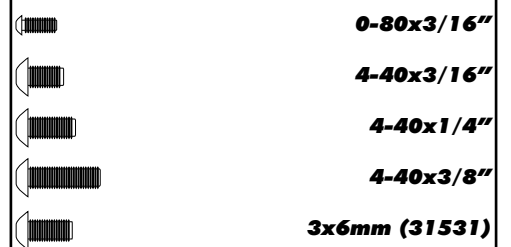

Diff Balls



Bushings

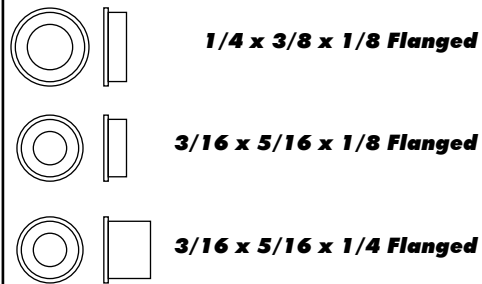

Set Screws



Nuts (lock/plain)

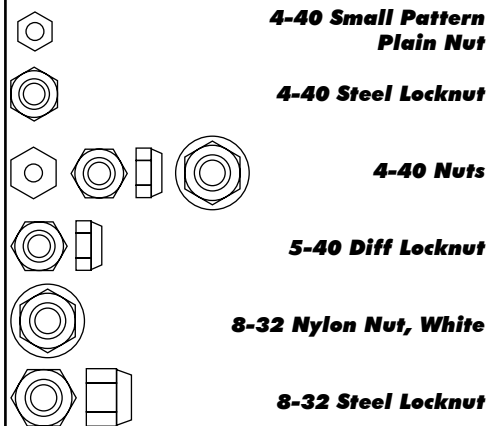

Shims and Washers

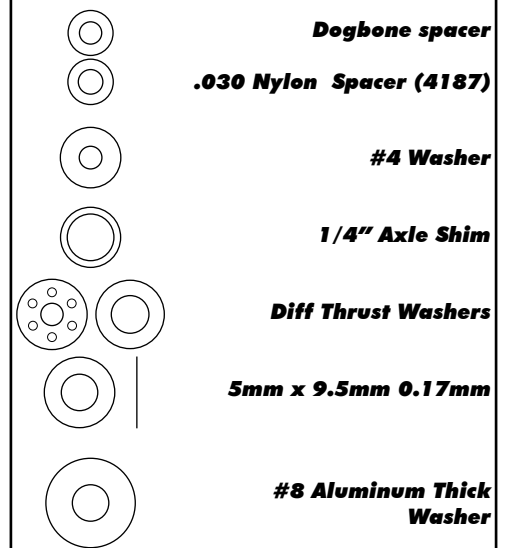

Clips



Notes:

:: Table of Contents

1..... Cover	12 - 13..... Turnbuckles Build (Bag F)
2..... Introduction	13 - 15..... Shocks Build (Bag G)
3..... 1:1 Hardware "Fold Out"	16 Chassis Build (Bag H)
4..... Table of Contents	16 - 18..... Electronics Build (Bag I)
5..... Nose Plate / Steering Build (Bag A)	18 - 20..... Wheels, Tires and Body Install (Bag J)
5 - 6..... Front Suspension Build (Bag B)	21..... Notes
7 - 10..... Transmission Build (Bag C)	22..... Back Cover
10 - 11..... Rear Bulkhead Build (Bag D)	
11 - 12..... Rear Suspension Build (Bag E)	

:: Notes



This symbol indicates a special note or instruction in the manual.



There is a 1:1 hardware foldout page in the front of the manual. To check the size of a part, line up your hardware with the correct drawing until you find the exact size.

Associated Electrics, Inc.
21062 Bake Parkway
Lake Forest, CA 92630



Customer Service
Tel: 949.544.7500
Fax: 949.544.7501

:: Nose Plate / Steering Build - Bag A - Step 1

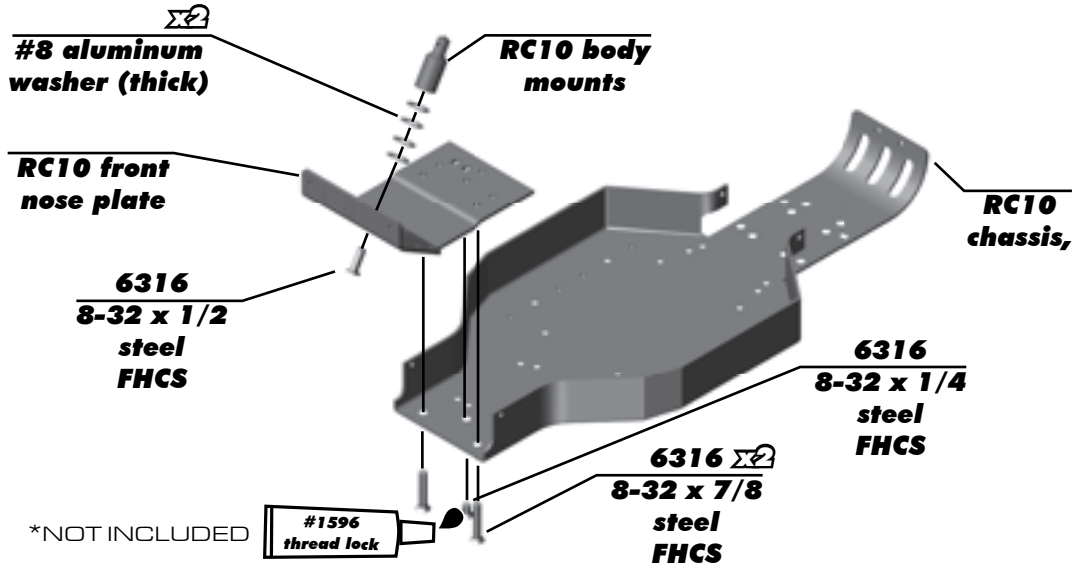

:: Nose Plate / Steering Build - Bag A - Step 2

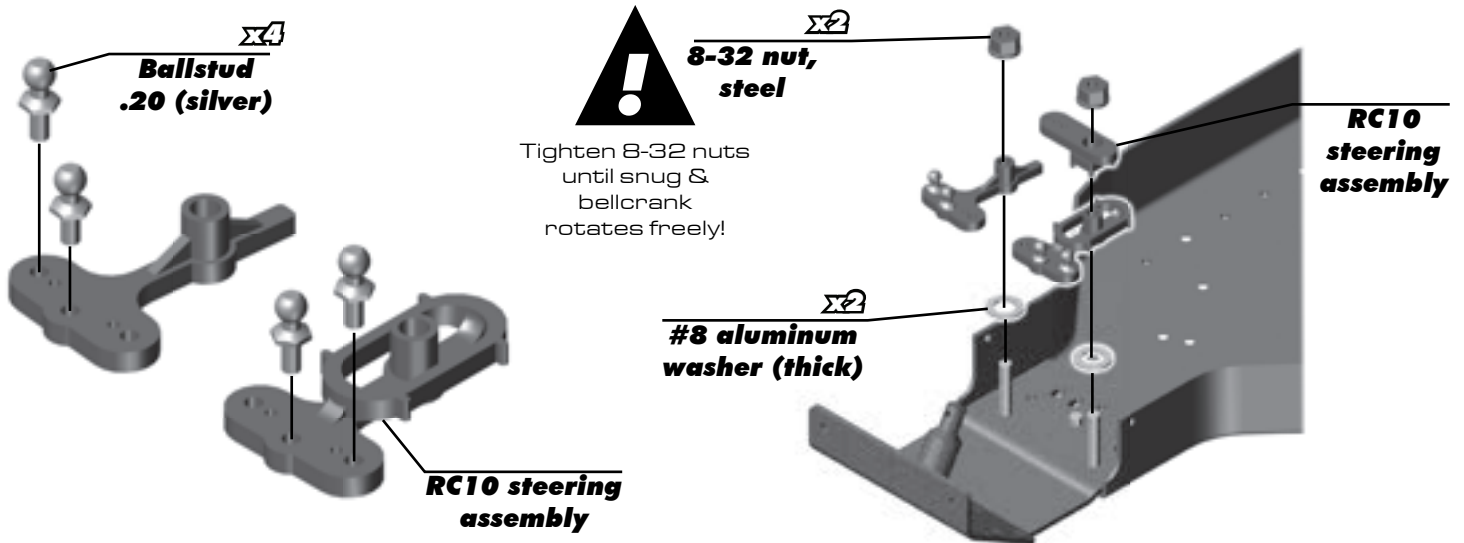

:: Front Suspension Build - Bag B - Step 1

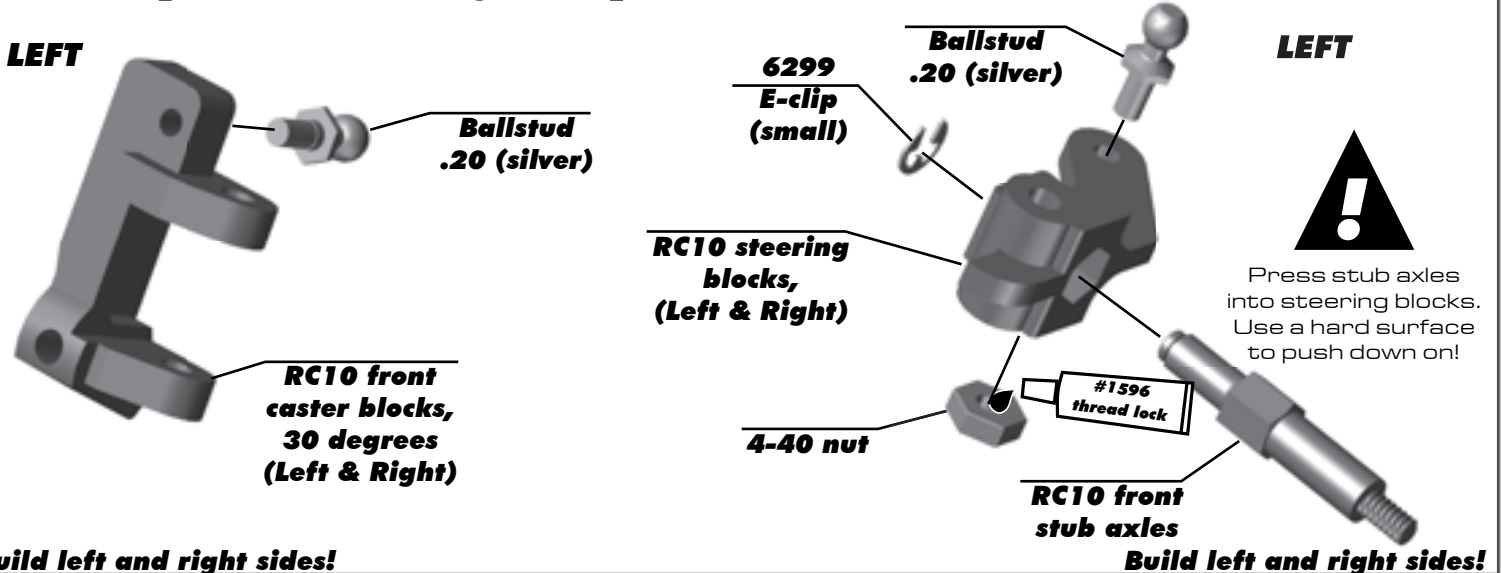

:: Front Suspension Build - Bag B - Step 2

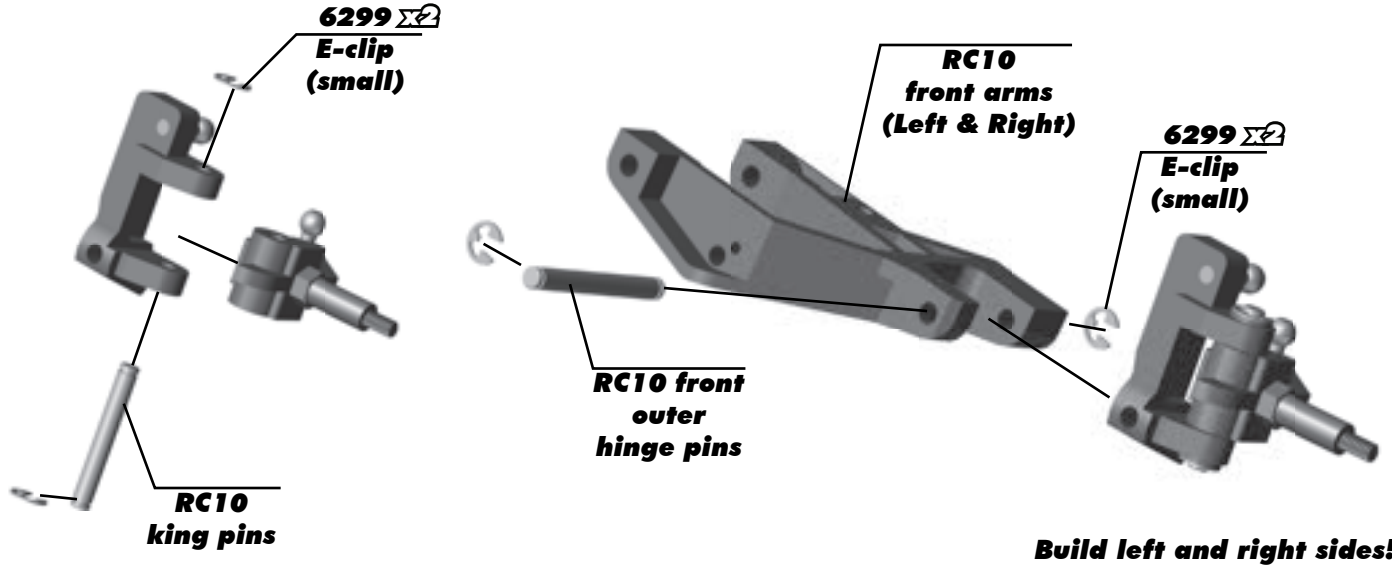

:: Front Suspension Build - Bag B - Step 3

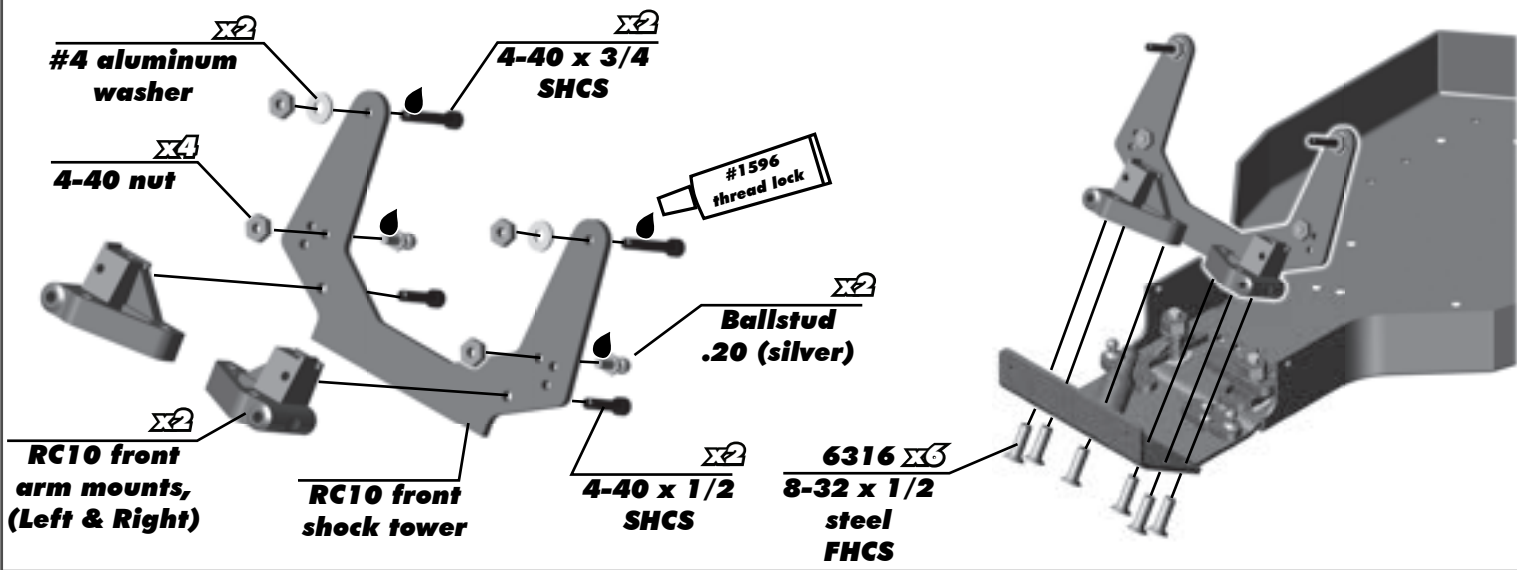

:: Front Suspension Build - Bag B - Step 4

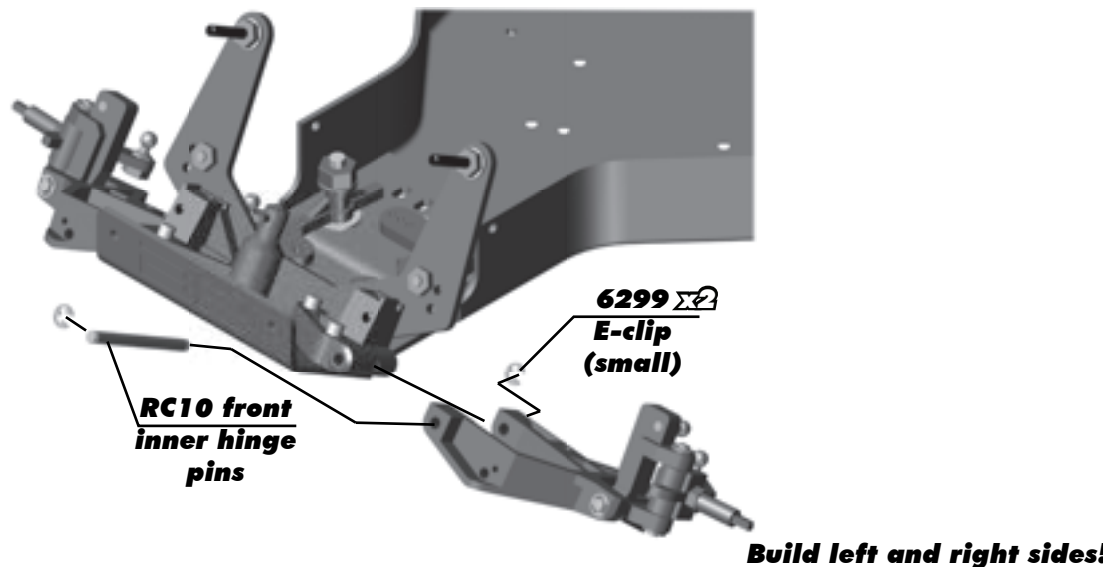

:: Transmission Build - Bag C - Step 1

Drive gear pivot pin

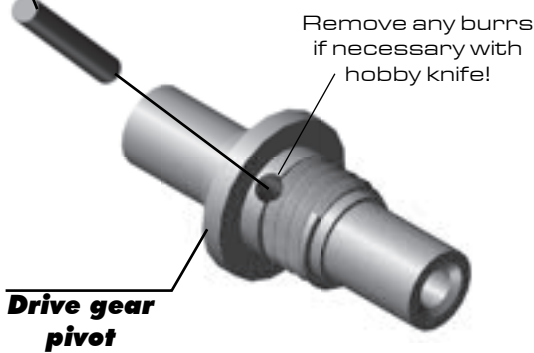

RC10 spine plate

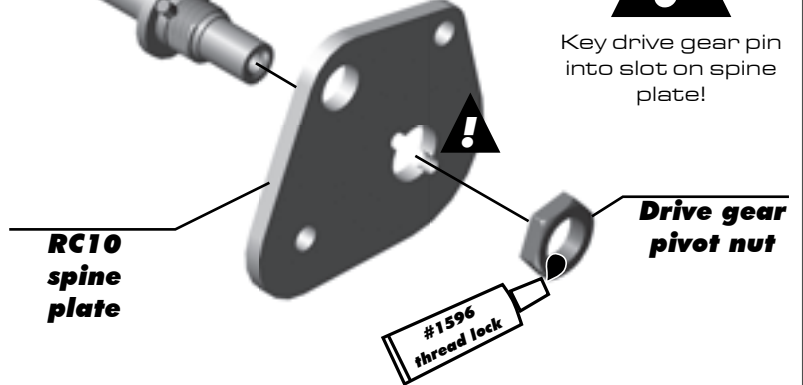

:: Transmission Build - Bag C - Step 2

RC10 idler gear pivot

NOTE: Install washer [1] before bowed e-clip [2]

Bowed e-clip

2

1

Washer 5mm 0.17mm

!
Curved side of bowed E-Clip should point outwards!

!
Racer's Tip:
Use a small amount of CA glue on idle pivot hole.

:: Transmission Build - Bag C - Step 3

Oilite bushing 3/16x5/16x1/4

RC10 axle drive gear

!
A little in-out play is normal on the outdrives

#1596 thread lock

!
Snap internal retaining clip into groove with internal snap ring pliers!

RC10 internal retaining clip

#1596 thread lock

4-40 x 3/16 BHCS

Build 2

:: Transmission Build - Bag C - Step 4

Oilite bushing
3/16x5/16x1/8

RC10 idler gear

6299 E-clip (small)

0-80 x 3/16 BHCS

Build 2

! Carefully tighten screws in x-pattern!

x4

:: Transmission Build - Bag C - Step 5

RC10 diff shaft and pinion

#6538 black grease

RC10 diff thrust washers (small & large)

RC10 diff pinion

RC10 bearing adapter

Oilite bushing
1/4 x 3/8 x 1/8

RC10 diff tube w/hub

RC10 diff thrust bearing

RC10 diff bushing

#6636 silicone lube

Bushing

! Slip the gear onto the tube and tap the assembly together using the handle of a hammer or a plastic handle of a screwdriver. Do not use a vise!

! Use just enough black grease to cover the balls on the thrust bearing!

! Use #6636 silicone lube on the inside of diff pinion

! Press bushing in, make sure it is flush with diff hub!

:: Transmission Build - Bag C - Step 6

Spur gear 81T, 48P

#6636 silicone lube

1/8 diff balls

Diff drive rings

! Apply silicone grease into each hole of the spur gear before inserting diff balls. Insert diff balls opposite of stamped number on spur gear. Make sure they are evenly covered in lube!

! **Caution:** Do not get any grease on the back side of the diff drive rings on the diff hub.

! Make sure diff rings sit flat on hub!

:: Transmission Build - Bag C - Step 7

Caution:
Do not get any grease on the back side of the diff drive rings or the outer hub.

Diff drive rings

RC10 diff spring

5-40 locknut

RC10 diff outer hub

Make sure diff rings sit flat on hub!

Tighten locknut until spring is fully compressed, then back out until lock nut is flush with shaft end. Adjust as necessary.

:: Transmission Build - Bag C - Step 8

1

RC10 motor plate

RC10 transmission case (left)

RC10 transmission case (right)

RC10 bearing adapter

6299 E-clip (small)

Oilite bushing 3/16 x 5/16 x 1/8

2

Cutting a slot in the bearing adapter will make e-clip installation easier!

:: Transmission Build - Bag C - Step 9

RC10 felt

RC10 felt seal

4-40 plain nut (small)

Press nut all the way inside the transmission case.

:: Transmission Build - Bag C - Step 10

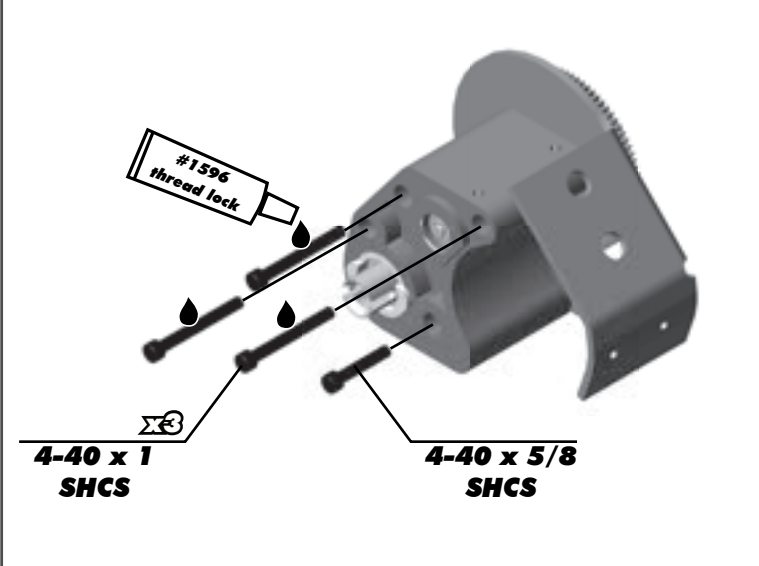

:: Rear Bulkhead Build - Bag D - Step 1

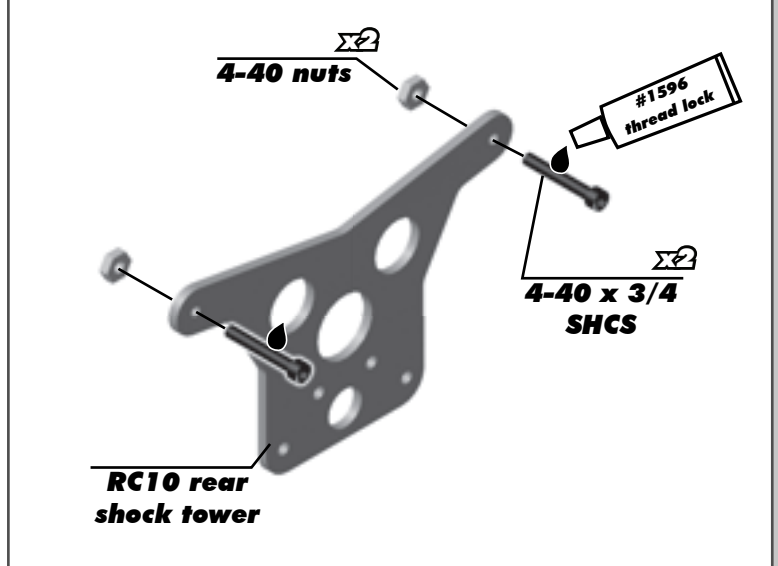

:: Rear Bulkhead Build - Bag D - Step 2

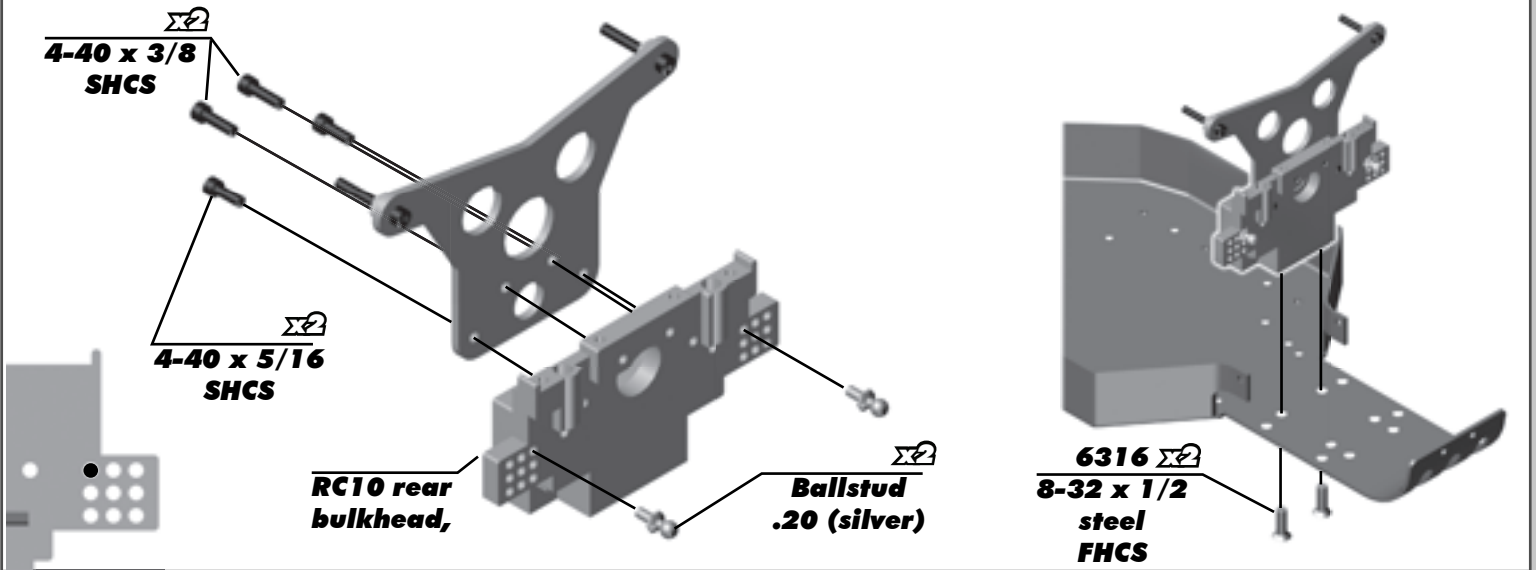

:: Rear Bulkhead Build - Bag D - Step 3

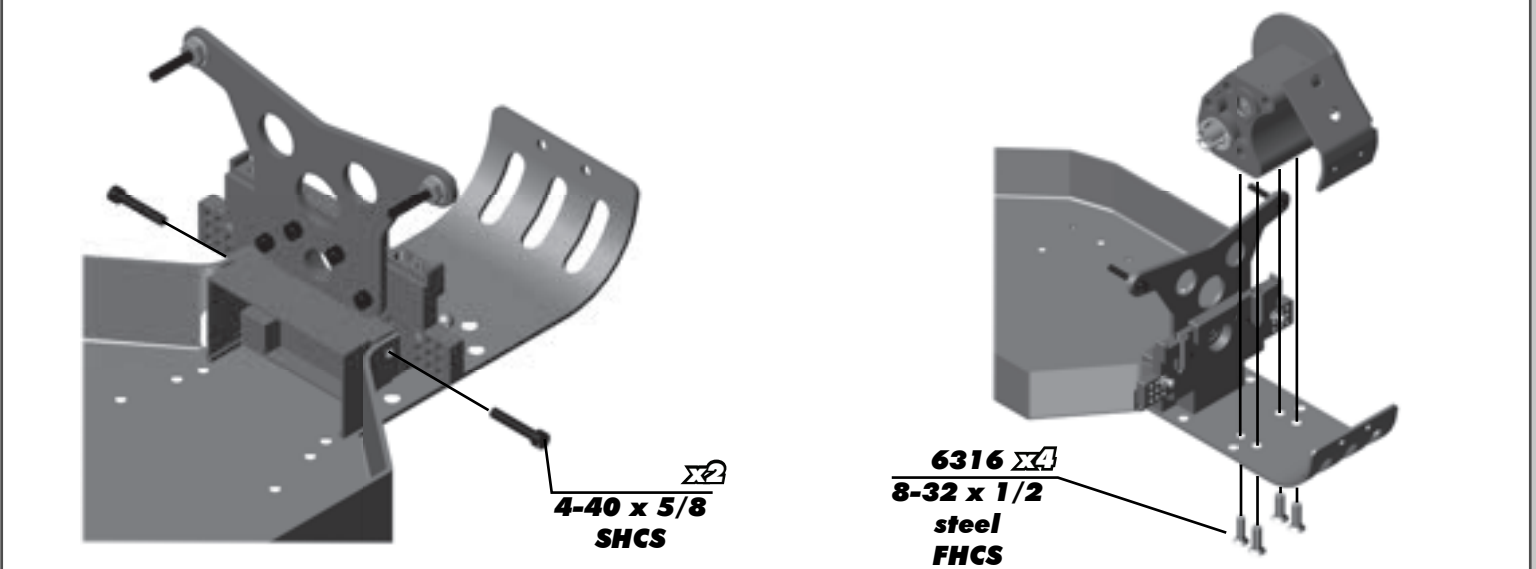

:: Rear Bulkhead Build - Bag D - Step 4

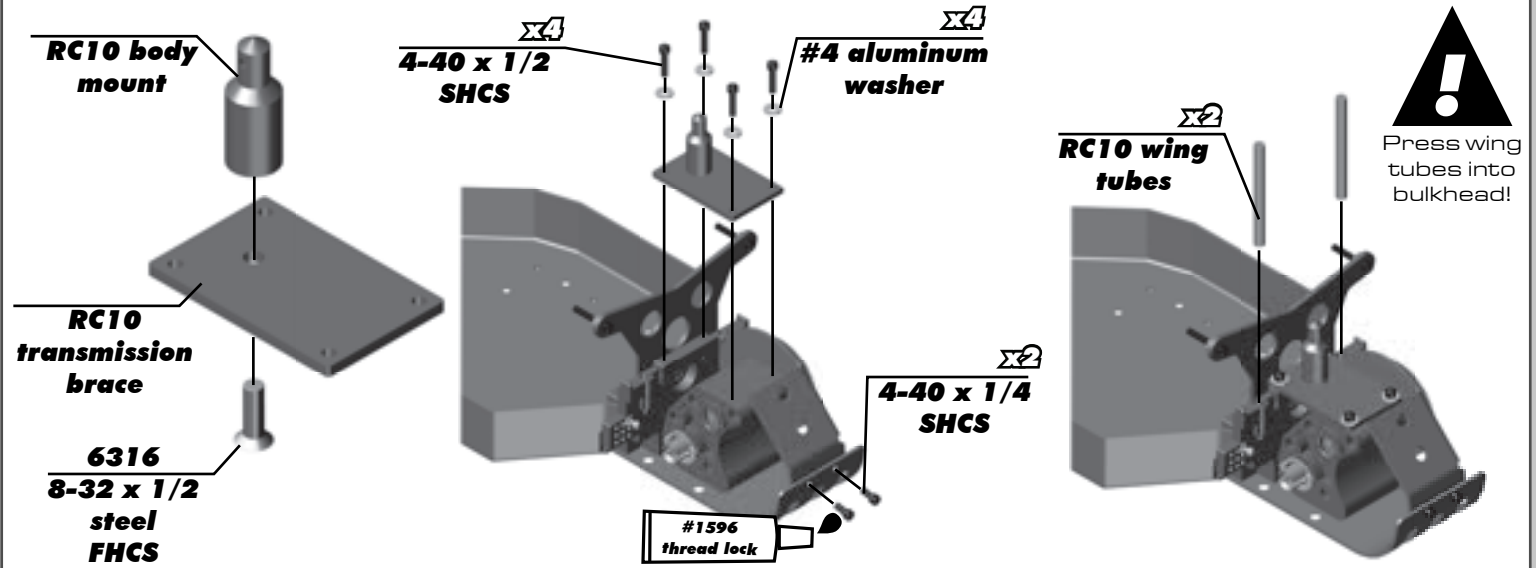

:: Rear Suspension Build - Bag E - Step 1

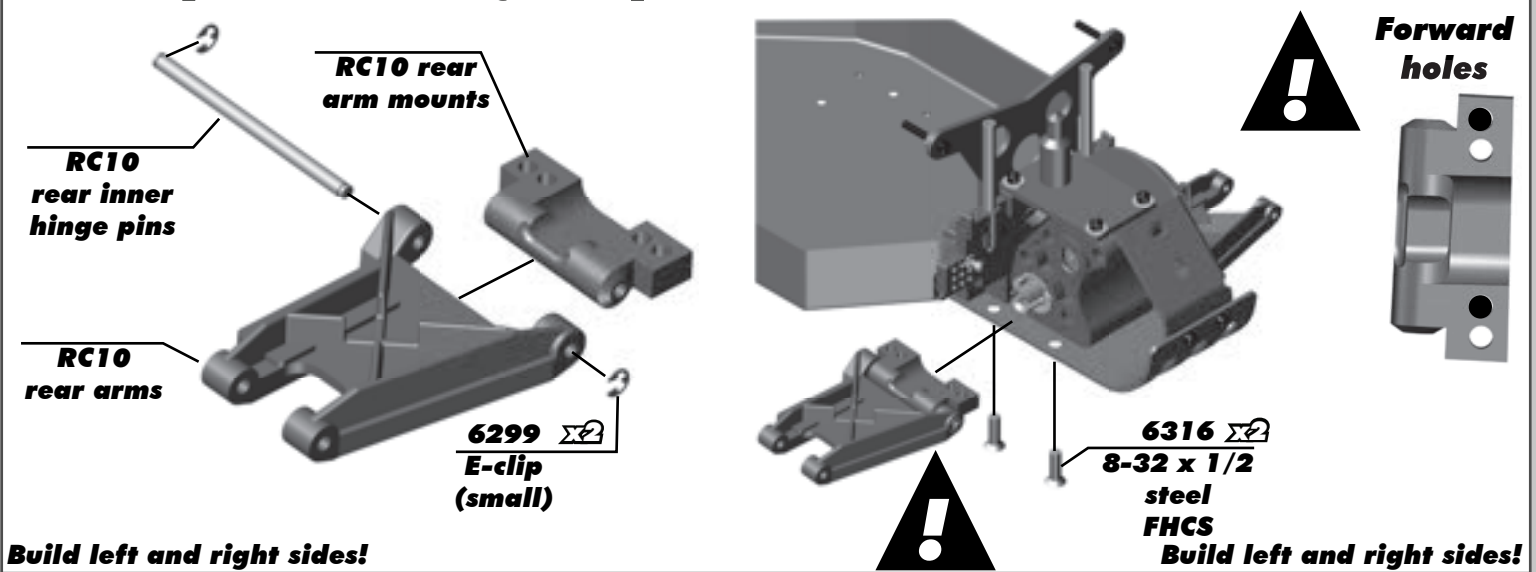

:: Rear Suspension Build - Bag E - Step 2

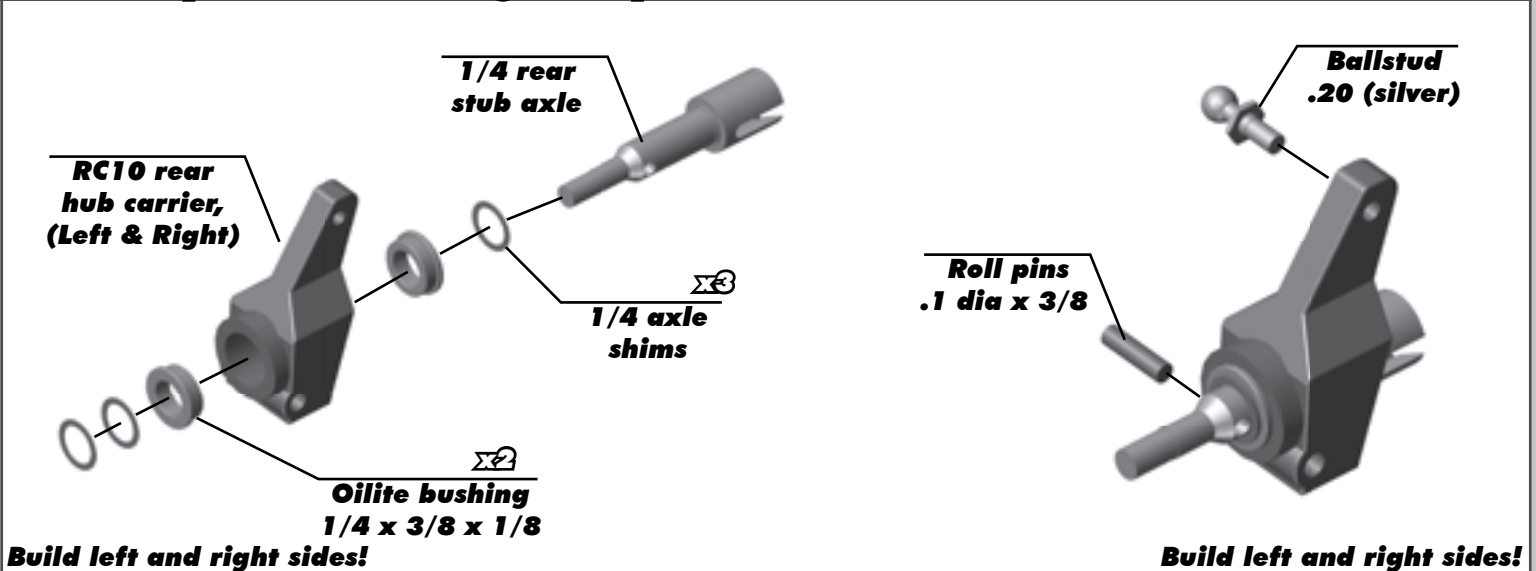

:: Rear Suspension Build - Bag E - Step 3

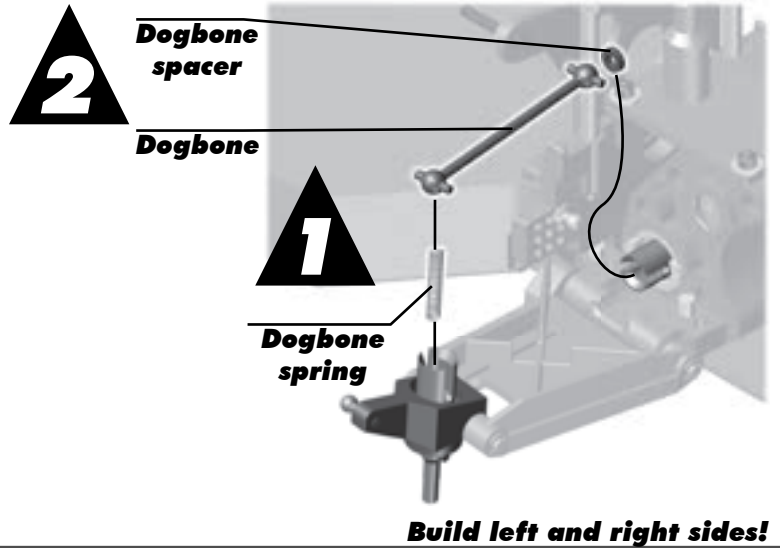
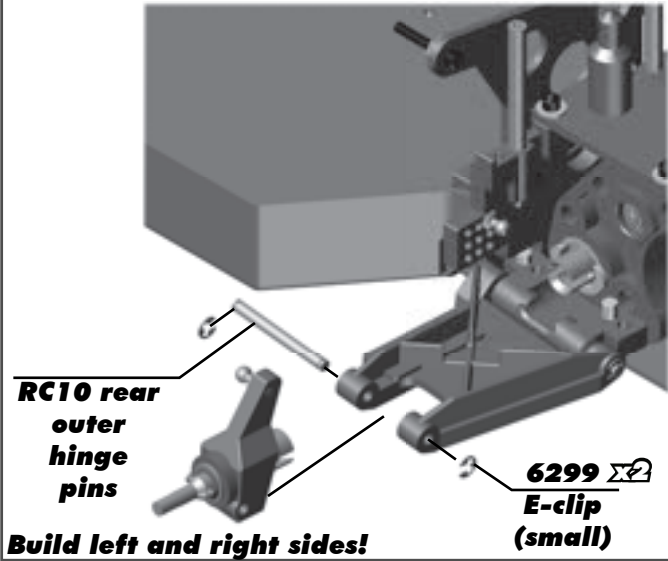

:: Turnbuckles Build - Bag F - Step 1

! Use a pair of pliers or wire cutters to carefully hold the turnbuckle while threading on ball cups.

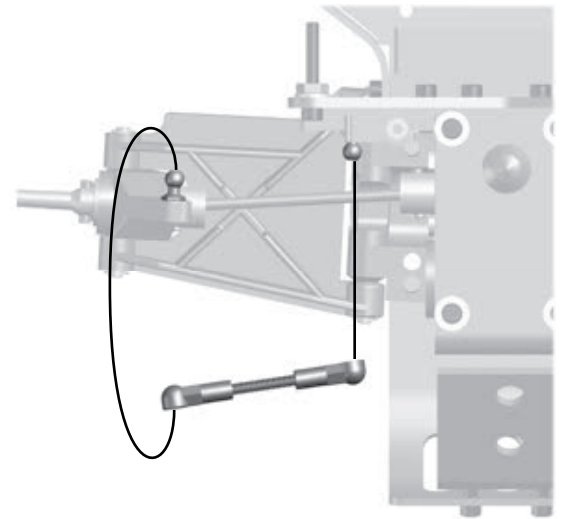
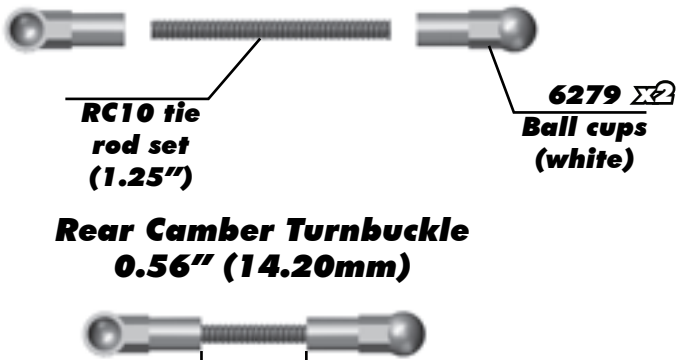

Build left and right sides!

:: Turnbuckles Build - Bag F - Step 2

! Use a pair of pliers or wire cutters to carefully hold the turnbuckle while threading on ball cups.

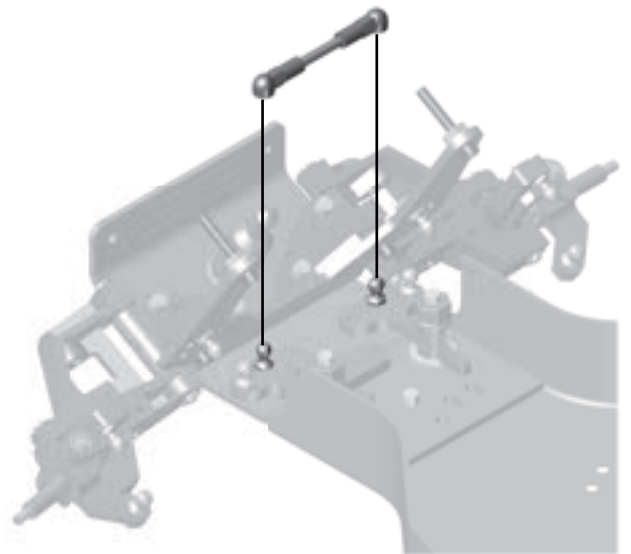
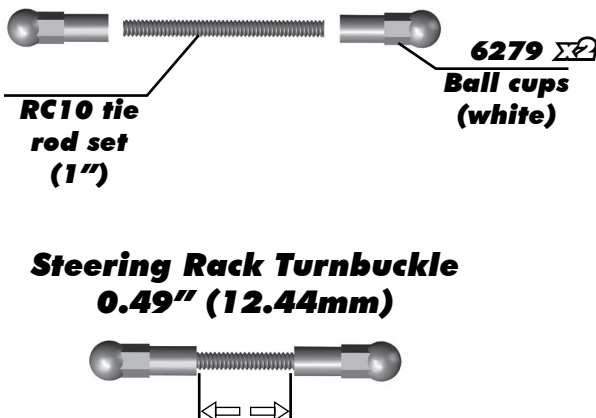

:: Turnbuckles Build - Bag F - Step 3



Use a pair of pliers or wire cutters to carefully hold the turnbuckle while threading on ball cups.



**Front Camber Turnbuckle
0.53" (13.5mm)**

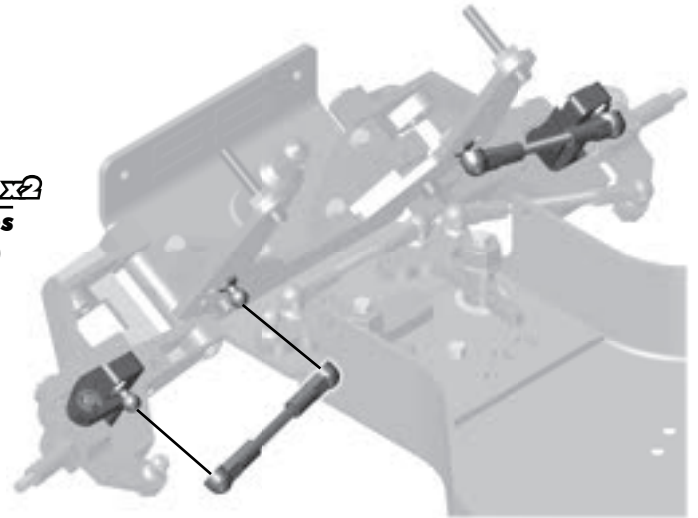
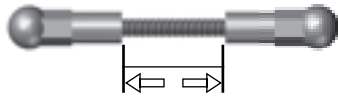

Build left and right sides!

:: Turnbuckles Build - Bag F - Step 4



Use a pair of pliers or wire cutters to carefully hold the turnbuckle while threading on ball cups.

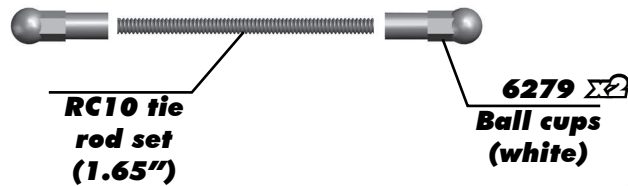

**Steering Turnbuckle
1.09" (27.70mm)**

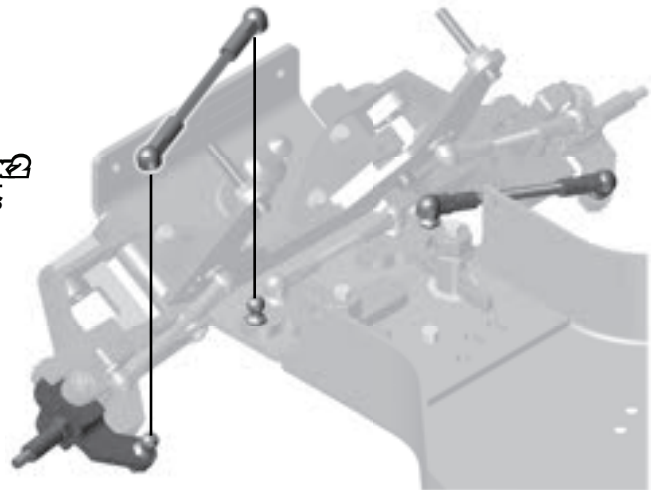

Build left and right sides!

:: Shocks Build - Bag G - Step 1

Remove spurs

Piston

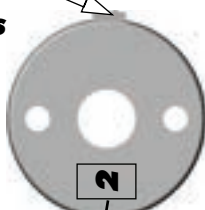

**Piston number here
Use #2 = front shocks
Use #2 = rear shocks**

**6299
E-clip
(small)**

**Shock shaft,
front (0.56)**

**Shock shaft,
rear (1.32)**

**Shock
pistons
(1, 2, 3)**

**6299
E-clip
(small)**

TIP: Use marker to mark the piston numbers for easy identification!

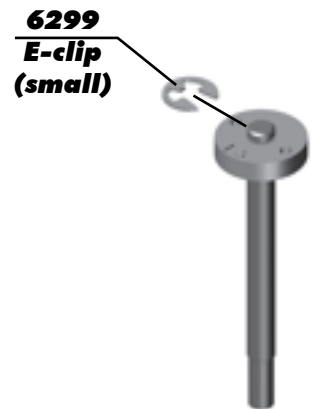
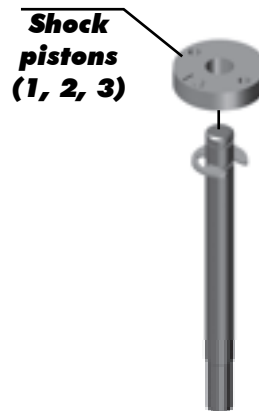
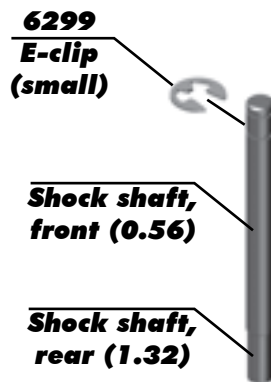

Build two front and two rear!

:: Shocks Build - Bag G - Step 2

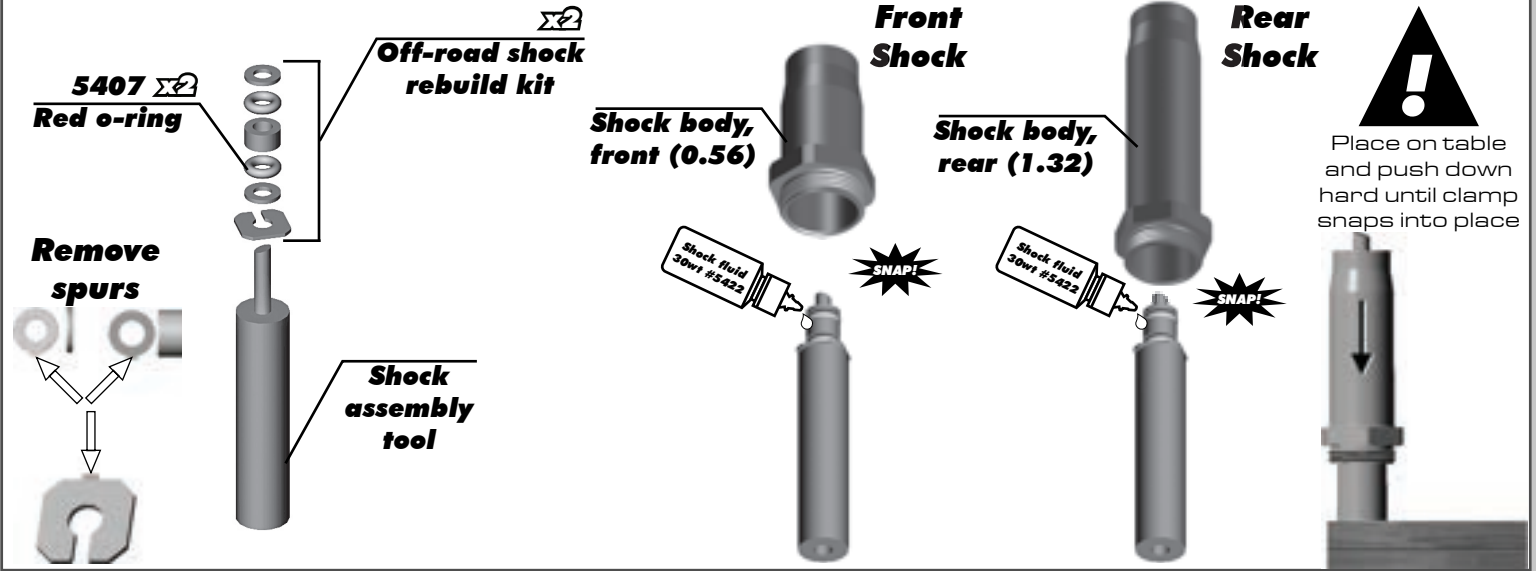

:: Shocks Build - Bag G - Step 3

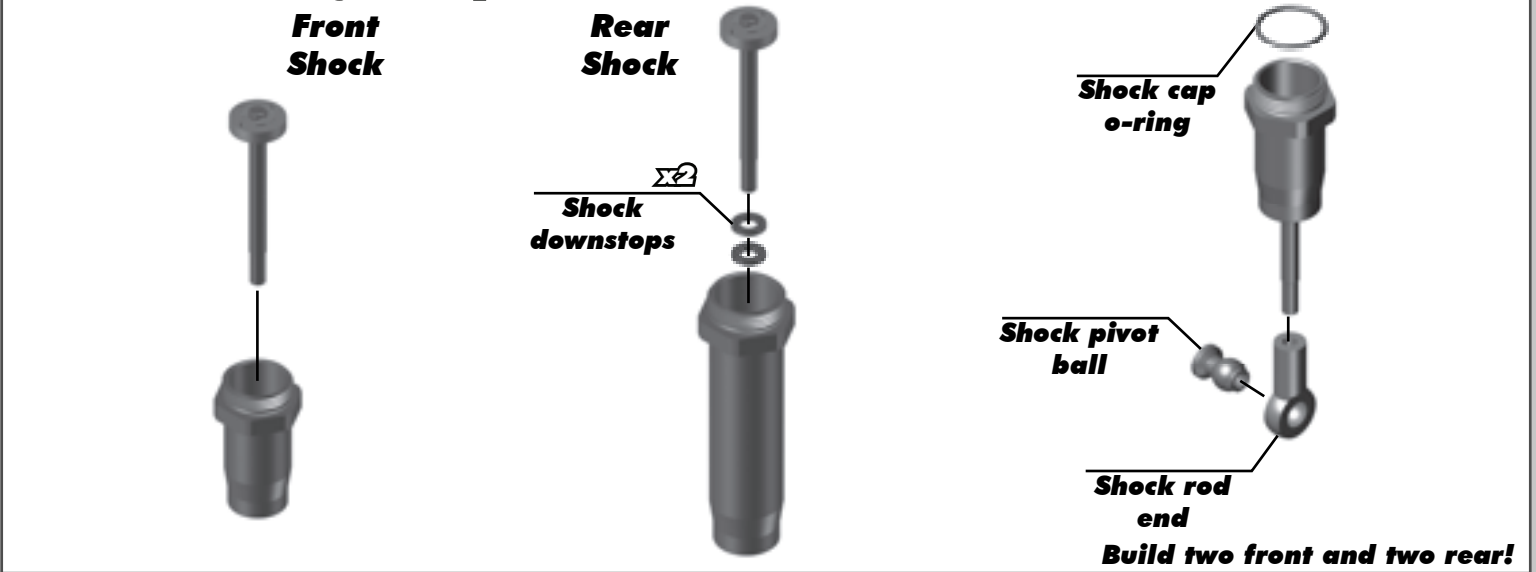

:: Shocks Build - Bag G - Step 4

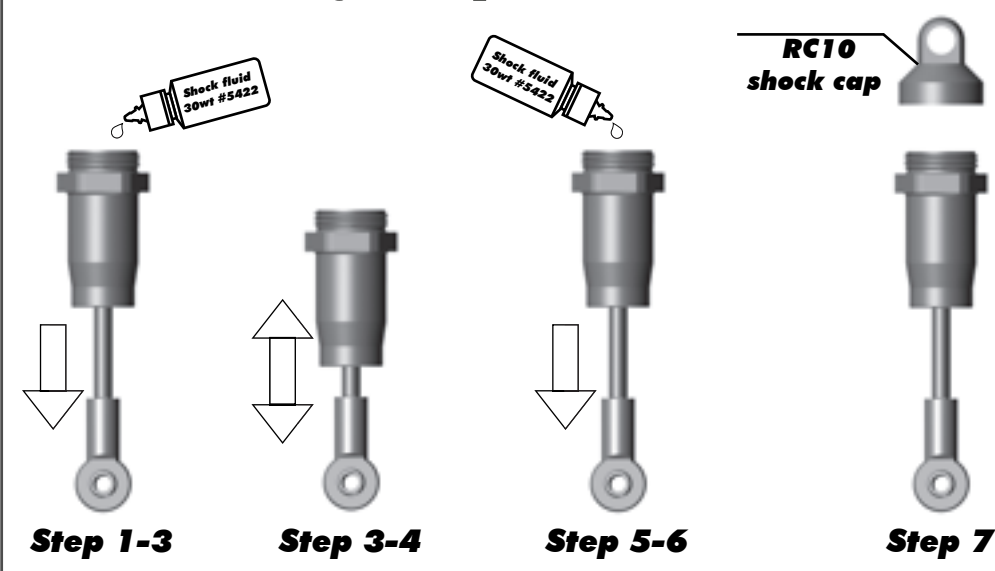

* Shock Bleeding Steps:

1. Pull shock shaft down.
2. Fill shock body 3/4 full with silicone fluid.
3. Slowly move the shock shaft up and down to remove air from under piston.
4. Wait for bubbles to come to surface.
5. Fill shock body to top with silicone fluid.
6. Place several drops of oil in the cap and on cap threads.
7. Install cap and tighten completely.
8. Slowly compress shaft all the way to the top. If there is pressure at the top of the stroke, there is too much oil. You must bleed it out.
9. Slowly pull shaft down.
10. Unscrew the cap 3/4 turn and tilt the shock at a slight angle.
11. Slowly compress the shaft to push out excess oil and air. You should see bubbles coming out from under the cap.
12. With the shaft compressed, tighten the cap and re-check for pressure at the top of the stroke. If there is still pressure, repeat steps 9 thru 11.

:: Shocks Build - Bag G - Step 5

RC10 shock collar

4-40 x 3/8 SHCS

Front shock spring, silver (3.85lb)

Rear shock spring, silver (2.10lb)

RC10 spring cup

Front: 6.5mm

Rear: 0mm

Build two front and two rear!

:: Shocks Build - Bag G - Step 6

#4 aluminum washer

4-40 locknut

RC10 shock bushing

4-40 x 1/8 set screw

Lower shock pin

Make sure the set screw engages the groove on the shock pin!

Build left and right sides!

Build left and right sides!

:: Shocks Build - Bag G - Step 7

#4 aluminum washer

4-40 locknut

RC10 shock bushing

4-40 x 3/4 SHCS

Build left and right sides!

:: Chassis Build - Bag H - Step 1

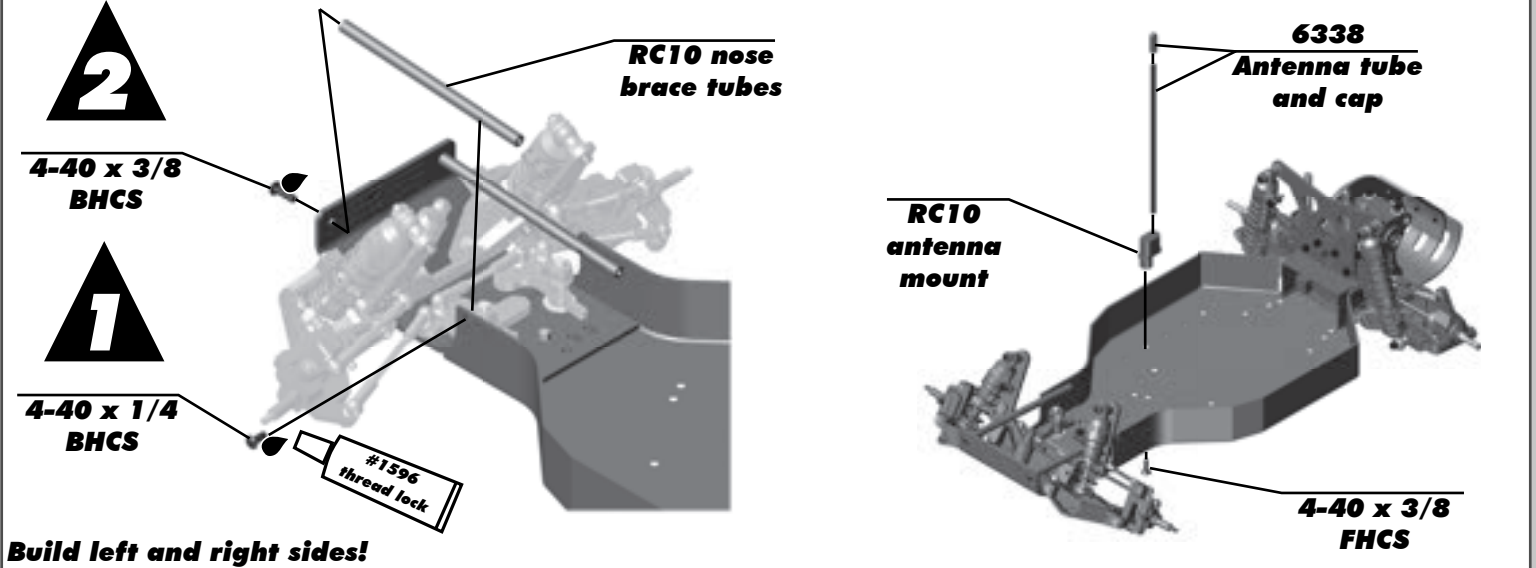

:: Electronics Build - Bag I - Step 1

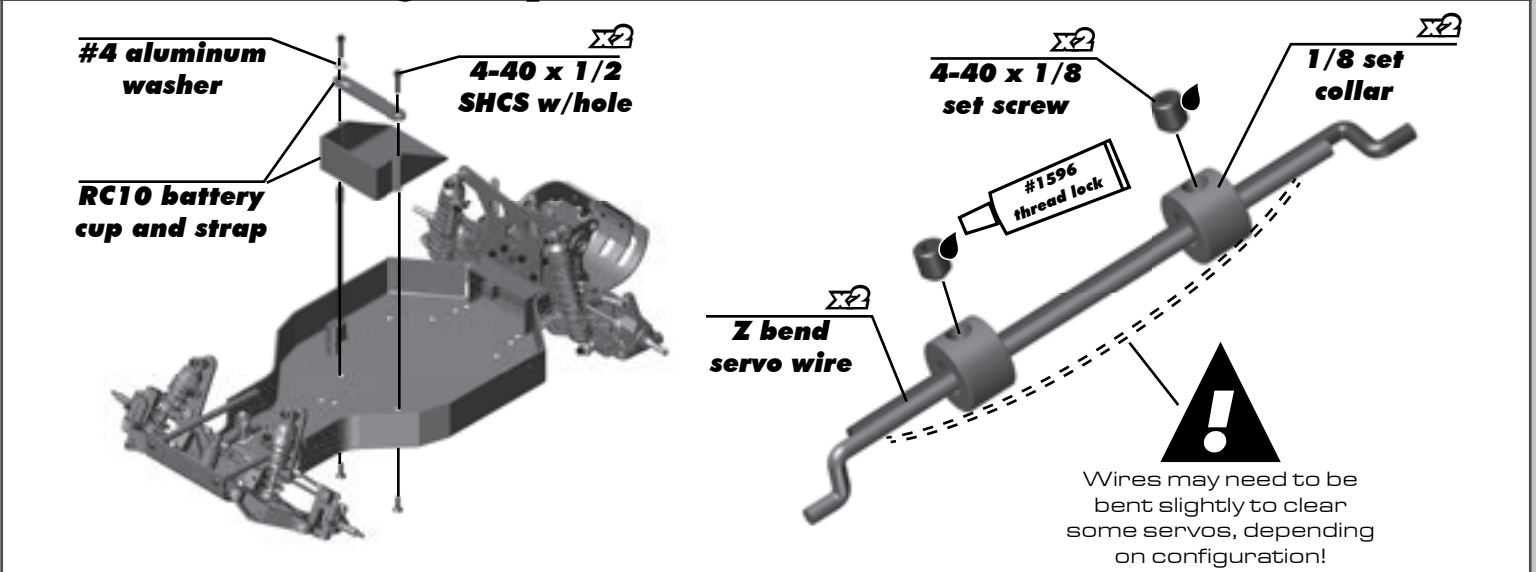

:: Electronics Build - Bag I - Step 2

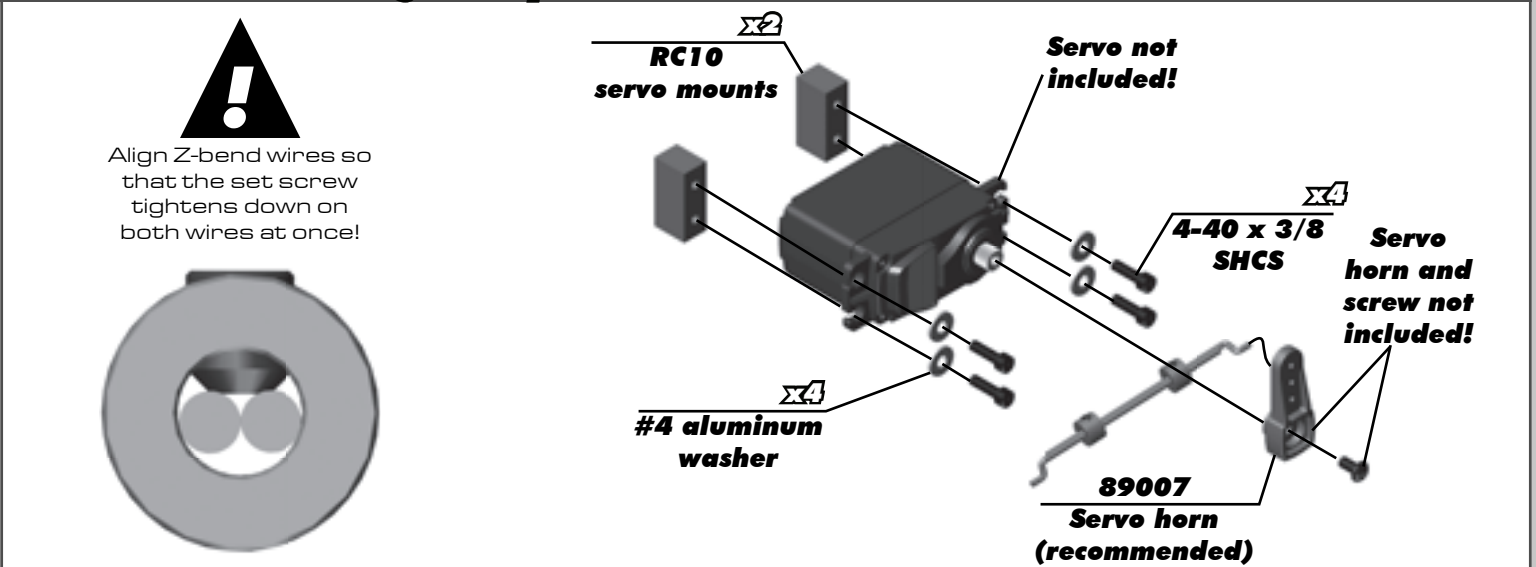

:: Electronics Build - Bag 1 - Step 3



Follow steps below to properly install Z bend wire into servo horn and steering link.

NOTE: Hole choice may vary depending on servo and servo horn used.

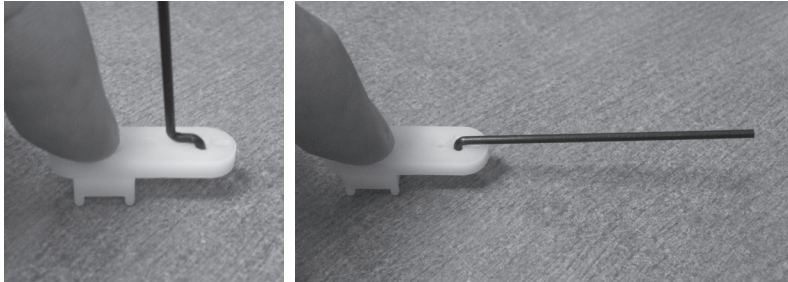

- 1) Press down on the Z bend wire....
- 2) Rotate the wire so the Z bend wire is fully installed into steering link as shown.

TIP: Chamfering the top of the hole slightly will help to press in Z bend wire.

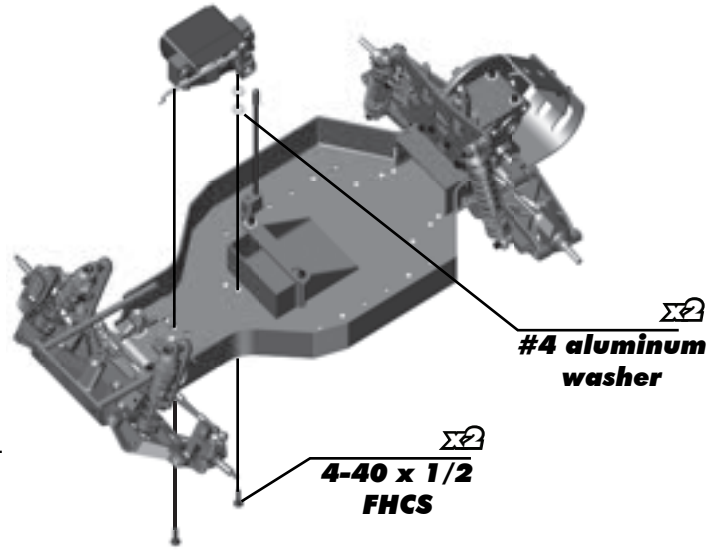

:: Electronics Build - Bag 1 - Step 4

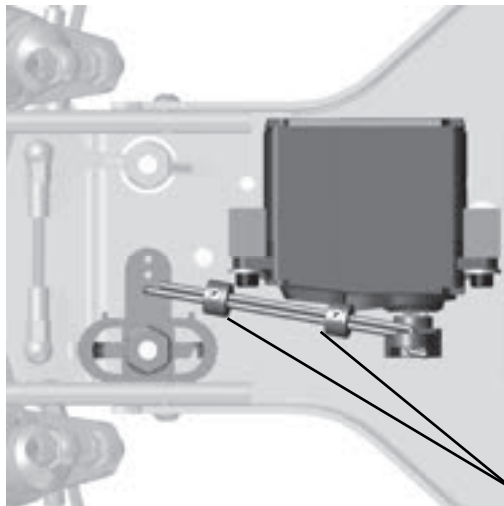

Install Z bend servo wire into steering bellcrank as shown. Ensure that full steering throw can be achieved with your servo horn setup!



Space collars as wide as possible while still clamping both wires.

Receiver not included!

ESC not included!

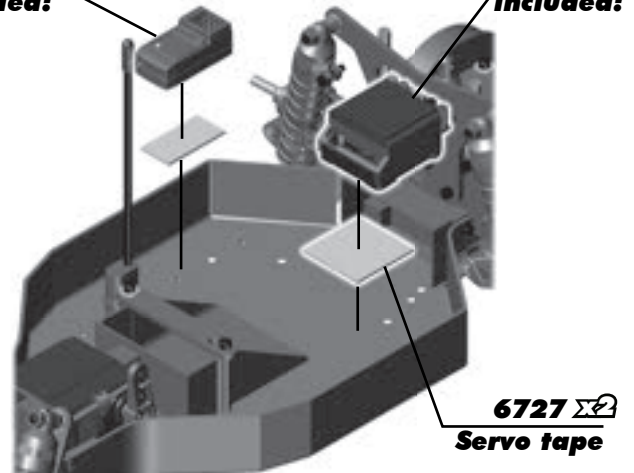

:: Electronics Build - Bag 1 - Step 5

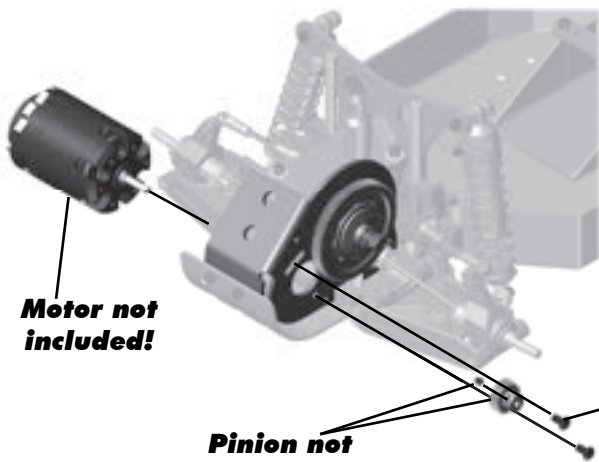

Motor not included!

Pinion not included!

31531 3 x 6mm BHCS

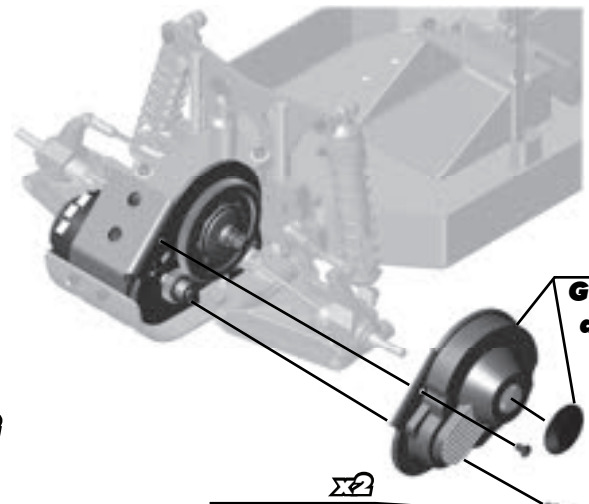

Gear cover and plug

4-40 x 3/16 BHCS

:: Electronics Build - Bag I - Step 6

Battery not included!

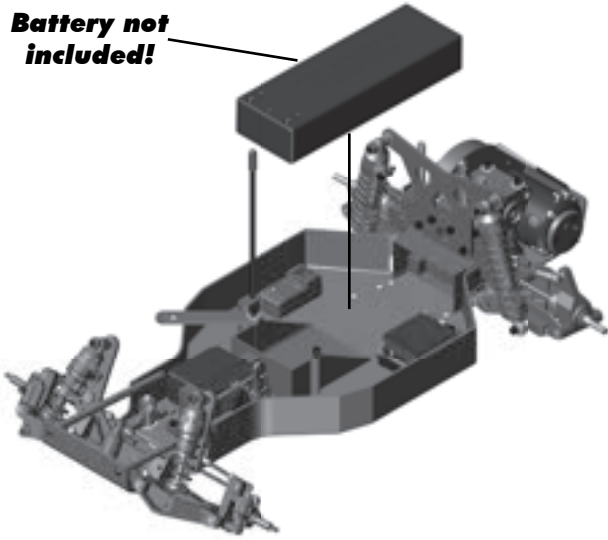

**6332
Body clip**

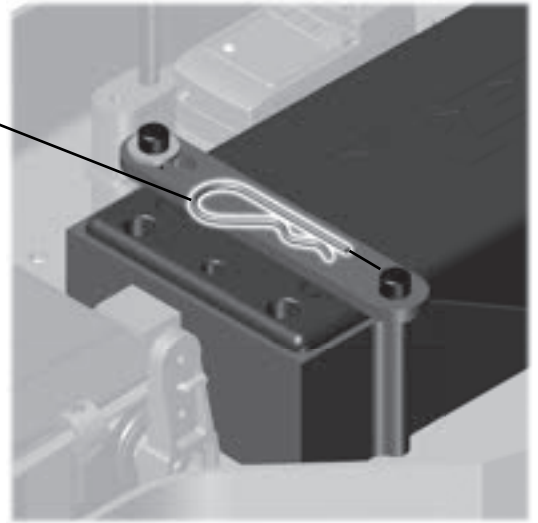

:: Wheels / Tires and Body - Bag J - Step 1

TIP: For faster motors, it is recommended to glue the tire bead to the wheels!

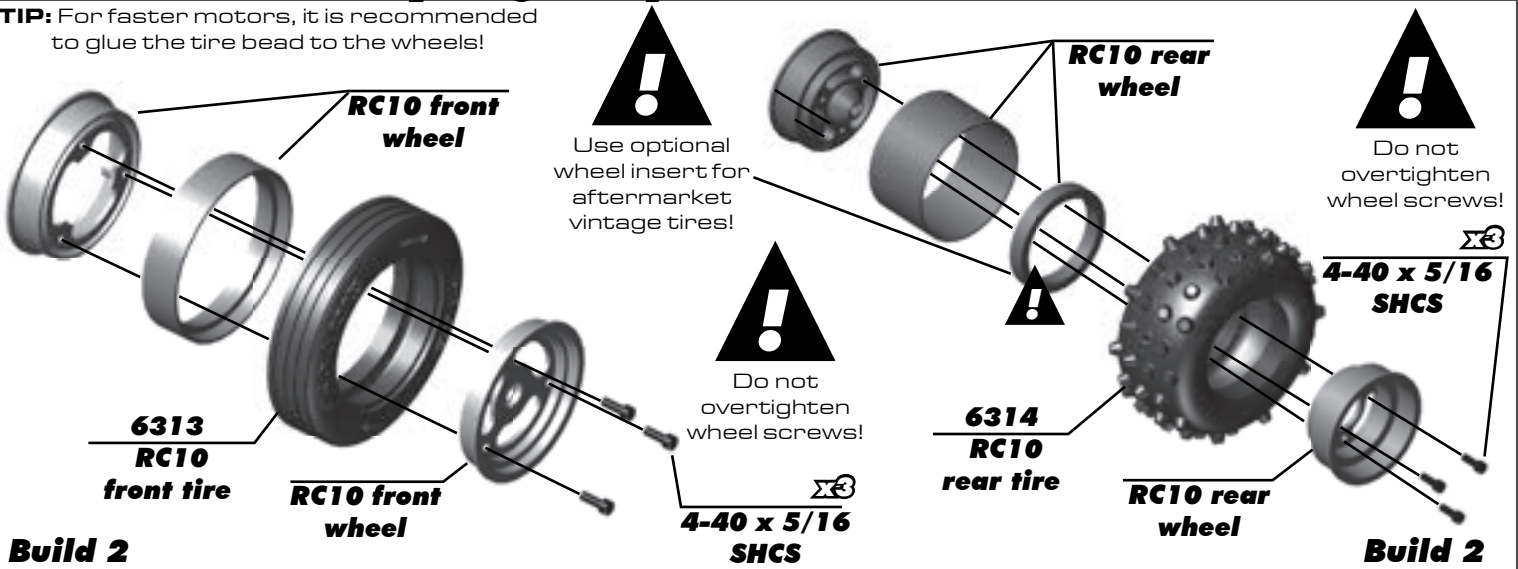

:: Wheels / Tires and Body - Bag J - Step 2

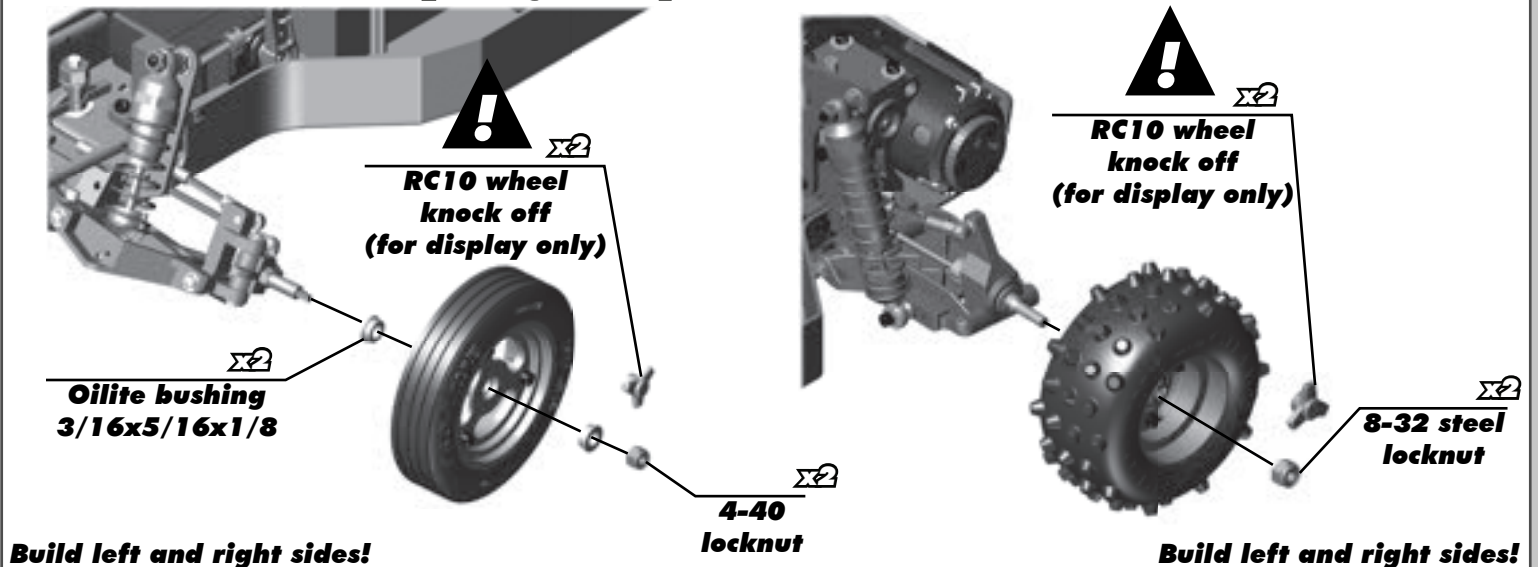

:: Wheels / Tires and Body - Bag J - Step 3

Painting Tips:

Your RC 10 Kit comes with a clear polycarbonate body and wing. You will need to prep the body and wing before you can paint them. Wash the inside thoroughly with warm water and liquid detergent. Dry the body and wing using a clean, soft, lint-free cloth. Use high quality masking tape to make masks for the windows and install them on the inside of the body (RC cars get painted from the inside).

Using high quality masking tape, apply tape to the inside of the body to create a design. Spray (either rattle can or airbrush RC specific paint) the paint to the inside of the body (preferably dark colors first, lighter colors last).

NOTE: use ONLY paint that is recommended for use with (polycarbonate) plastics. If you do not, you can destroy the plastic body and wing!!!!).

It is recommended to wear a mask while painting.

After the paint has dried, cut the body and wing along the trim lines. Make sure to drill or use a body reamer to make the holes for the body mounts, wing mounts, and antenna!

6159
RC10 Protec
Buggy body,
unpainted

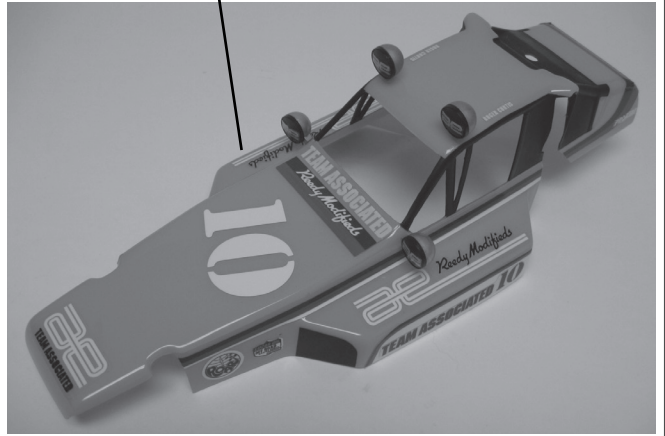

:: Wheels / Tires and Body - Bag J - Step 4

Light Buckets:

Press the light bucket halves together.
Install light buckets with 2-56 x 3/16 SHCS in areas shown.

Light
buckets

x4
2-56 x 3/16
SHCS

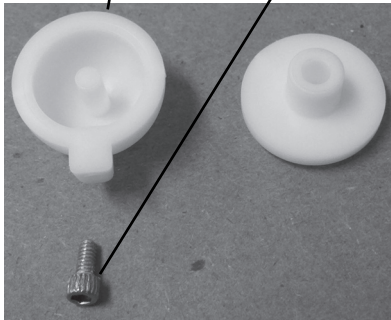

Mount the light buckets in any location of your choosing, or not at all.



:: Wheels / Tires and Body - Bag J - Step 5

Painting Tips:

Driver:
Your RC 10 Kit comes with a clear polycarbonate driver figure. You will need to prep the driver figure before you can paint it. Wash the inside and outside thoroughly with warm water and liquid detergent. Dry the driver figure using a clean, soft, lint-free cloth. The driver figure can be painted from the inside or the outside, depending on what type of finish you would like. If painted from the inside, the painted sections will appear glossy. If painted on the outside, the painted sections will appear flat or matte finished. Trim as shown and install inside the body using strapping tape. After painting, cut the body and wing along the trim lines.

NOTE: use ONLY paint that is recommended for use with (polycarbonate) plastics. If you don't, you can destroy the plastic body, driver figure, and wing!!!!.

RC10 driver
figure, clear



:: Wheels / Tires and Body - Bag J - Step 6



:: Wheels / Tires and Body - Bag J - Step 7

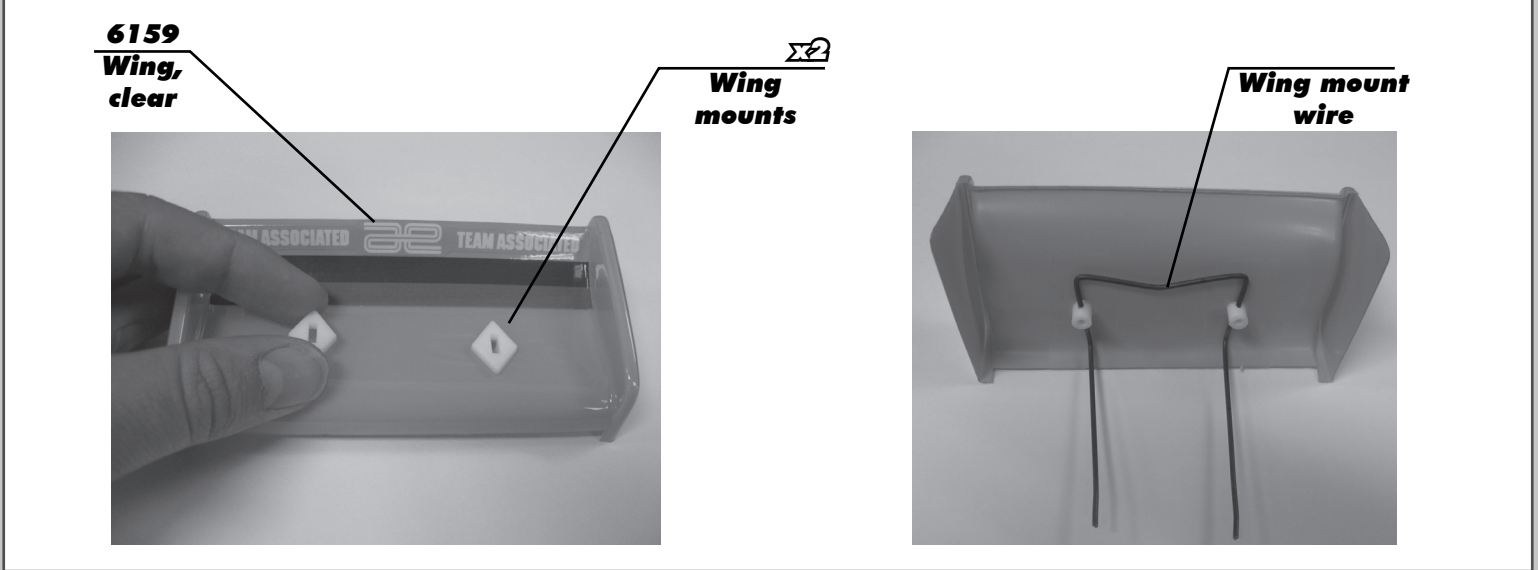

:: Wheels / Tires and Body - Bag J - Step 8

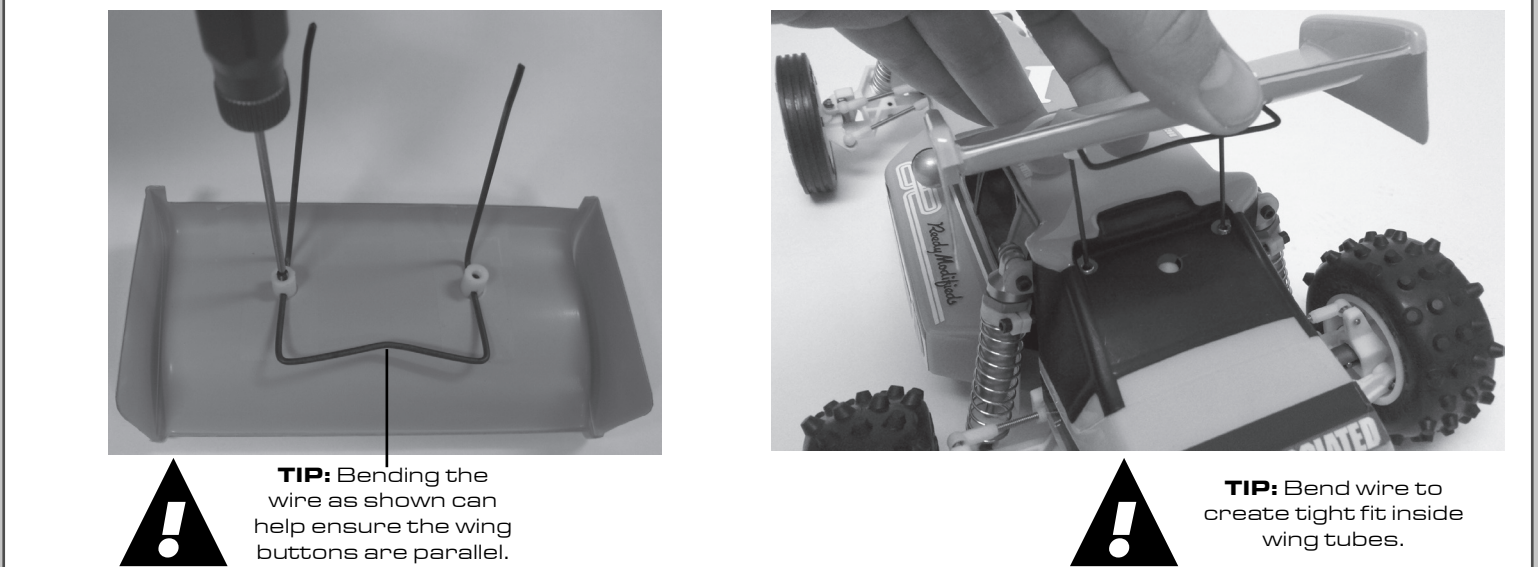

TIP: Bending the wire as shown can help ensure the wing buttons are parallel.



TIP: Bend wire to create tight fit inside wing tubes.

:: Notes

Blank area for notes.

FIND IT ON ASSOCIATEDELECTRICS.COM



Vehicle Spare Parts

GO TO:

[AssociatedElectrics.com](#) →
[Team Associated tab](#) →
[Cars & Trucks](#) →
[Scroll to your vehicle](#) →
[Parts & Accessories link](#)



Setups and Manuals

GO TO:

[AssociatedElectrics.com](#) →
[Team Associated tab](#) →
[Manuals & Setups](#) →
[Scroll to your vehicle](#)



Tuning Guides & Tips

GO TO:

[AssociatedElectrics.com](#) →
[Support](#) →
[A-Team Apps](#)



Associated Electrics, Inc.

21062 Bake Parkway Lake Forest, CA 92630 USA

call: (949) 544-7500 - fax: (949) 544-7501

**Check out the following web sites for all of our kits, current products,
new releases, setup help, tips, and racing info!**

www.AssociatedElectrics.com

FOLLOW US ON SOCIAL MEDIA



TeamAssociated
ReedyPower
ElementRC
Factory Team



@TeamAssociatedRC
@ReedyPower
@Element_RC
@FactoryTeam_RC



@Team_Associated
@ReedyPower



@Associated_Electrics